

Fig No: GT-200

MATERIALS LIST

NO.	PART NAME	MATERIAL
1	BODY	1.4408 / EN1503-1
4	DISC	1.4408 / EN1503-1
5	STEM	SS316
9	BONNET	1.4408 / EN1503-1
11	BODY SEAL	PTFE.
14	STEM PACKING	PTFE.
15	GLAND	SS304
16	GLAND NUT	SS316
19	HANDWHEEL	MICO STEEL
23	H.W. WASHER	SS304
24	H.W. NUT	SS304
25	NAME PLATE	ALUMINUM
33	STOP RING	SS304

DIMENSIONS

unit:mm

SIZE	PORT	L	ØE	H
DN15	1/2"	15.0	55.0	70.0
DN15	1/2"	15.0	55.0	92.0
DN20	3/4"	20.0	60.5	70.0
DN20	3/4"	20.0	60.5	97.0
DN25	1"	25.0	65.5	80.0
DN25	1"	25.0	65.5	108.5
DN32	1-1/4"	32.0	76.5	80.0
DN32	1-1/4"	32.0	76.5	123.5
DN40	1-1/2"	40.0	85.5	90.0
DN40	1-1/2"	40.0	85.5	146.0
DN50	2"	50.0	95.5	100.0
DN50	2"	50.0	95.5	162.0

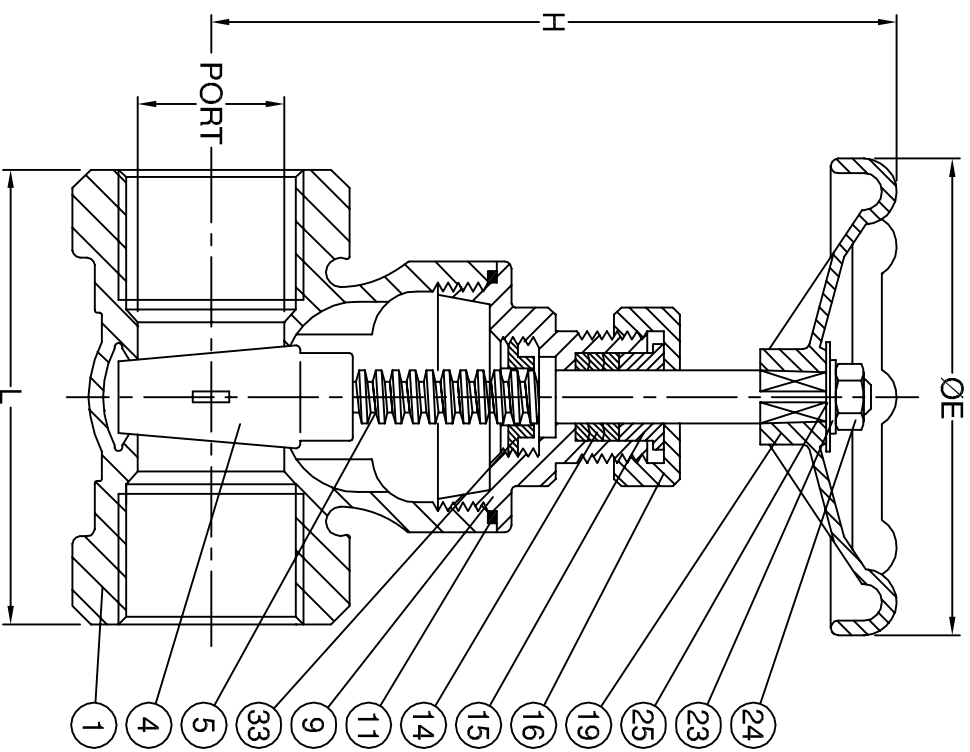

CODE	E-005	APPROVED BY.	CHECK BY.	DRAWN BY.	DRAWING NO.	MATERIAL	UNIT	DESCRIPTION
MODENTIC INDUSTRIAL CORPORATION	SIGN	PRESTON	SHANA	POOLER	GT-200-E005	MATERIALS LIST	mm	STAINLESS STEEL GATE VALVE, THREADED END, PN 16
	DATE	12/19/2007	12/19/2007	12/19/2007	REVISION	SCALE	FREE	

1 2 3 4 5 6 F E D C B A