

Fig No. K-301T Standard Bore
1/4" ~ 2" DN 8- DN 50



Features :

- Investment casting, Blow-out-proof stem
- Three pieces end caps, Three seats design
- 360 degree rotation design
- For Chemical, Industrial Application
- Carbon Steel or Super Alloy upon request

Standard Compliance :

- Body wall thickness : EN 12516-1/3
- Threaded end : BS 21 (BSP)
- BSPT
- ISO 228-1G
- DIN 2999
- ISO 7-1Rp
- Face to Face : MD's standard
- Body material : EN1503-1
- Pressure testing : EN 12266

Specification :

- End connection : Threaded end
- Working Pressure : 63 bar (CWP)
- Temperature : -20 to 180°C

MATERIALS LIST

NO.	PART NAME	MATERIAL
1	BODY	1.4408/EN1503-1
4	BALL	ASTM A351 Gr.CF8M
5	STEM	SS316
9	END CAP	1.4408/EN1503-1
10	BLIND CAP	1.4408/EN1503-1
11	BODY SEAL	PTFE.
12	SEAT	PTFE.
13	THRUST WASHER	PTFE.
14	STEM PACKING	PTFE.
16	GLAND NUT	SS304
19	HANDLE	SS304
21	HANDLE COVER	PLASTIC
23	HANDLE WASHER	SS304
24	HANDLE NUT	SS304
28	LOCKING DEVICE	SS304
59	FLOW INDICATOR	SS304

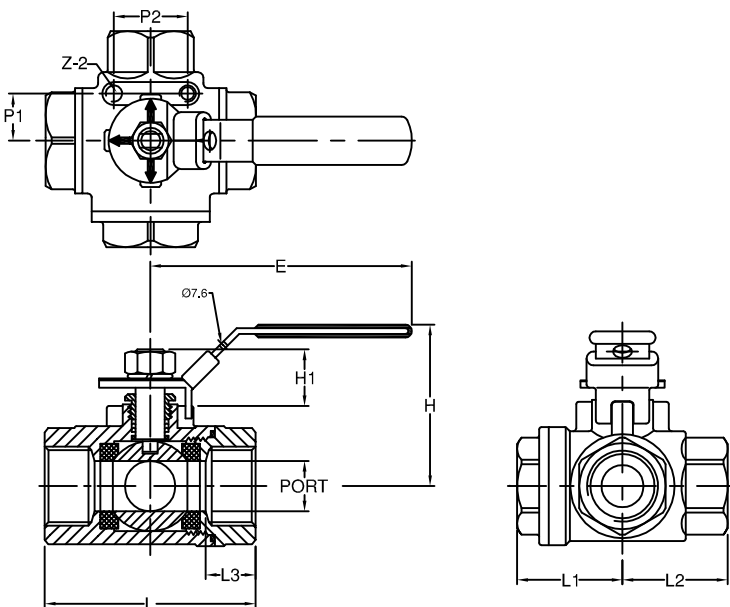
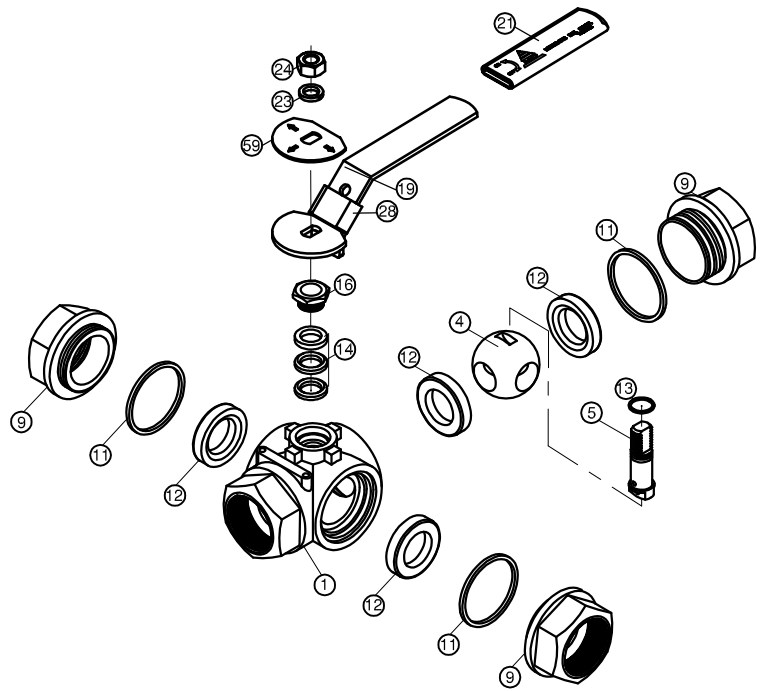

DIMENSIONS

SIZE	PORT	L	L1	L2	L3	E	H	H1	Z-2	P1	P2	
DN8	1/4"	11.7	75.0	34.0	37.5	17.0	125.0	53.0	33.0	10-24UNC	12.7	28.5
DN10	3/8"	12.8	75.0	34.0	37.5	17.0	125.0	53.0	33.0	10-24UNC	12.7	28.5
DN15	1/2"	12.8	75.0	34.0	37.5	17.0	125.0	53.0	33.0	10-24UNC	12.7	28.5
DN20	3/4"	16.0	85.0	39.0	42.5	17.5	125.0	64.0	30.0	10-24UNC	22.4	35.0
DN25	1"	20.0	103.0	51.0	50.0	20.0	145.0	66.0	35.0	10-24UNC	22.4	35.0
DN32	1-1/4"	25.2	115.0	51.0	57.5	21.0	145.0	79.0	35.0	1/4"-20UNC	25.4	38.1
DN40	1-1/2"	32.2	125.0	58.0	62.5	22.0	205.0	83.0	44.0	1/4"-20UNC	25.4	38.1
DN50	2"	38.2	148.0	63.0	75.0	25.0	205.0	94.0	40.0	1/4"-20UNC	25.4	38.1

unit:mm